



QUICK START GUIDE
GUIDE DE DÉMARRAGE RAPIDE
GUÍA DE INICIO RÁPIDO

DX 9-HSN



Contents / Table des matières / Contenido

USAGE	1.0	Preparation / Préparation / Preparación
UTILISATION	2.0	Installation / Installation / Instalación
USO	3.0	Operation / Fonctionnement / Operación
	4.0	Unloading the tool / Déchargement de l'outil / Descarga de clavos herramienta

MAINTENANCE	5.0	Disassembly / Désassemblage / Desmontaje
MAINTENANCE	6.0	Cleaning / Nettoyage / Limpieza
MANTENIMIENTO	7.0	Checking pistons & Piston break / Vérification des pistons & Butée de piston / Verificación del piston & Anillo de retención
	8.0	Assembly / Assemblage / Ensamblaje
	9.0	Service / Entretien / Servicio

TROUBLESHOOTING	10.0	Piston jam – tool stays compressed / Piston coincé – outil coincé en position comprimée / Pistón atorado – La herramienta permanece comprimida
DÉPANNAGE		
SOLUCIÓN	11.0	Tool cannot be compressed / Impossible de comprimer l'outil / La herramienta no se puede comprimir
DE PROBLEMAS		

1.0 Preparation / Préparation / Preparación

DX 9-HSN

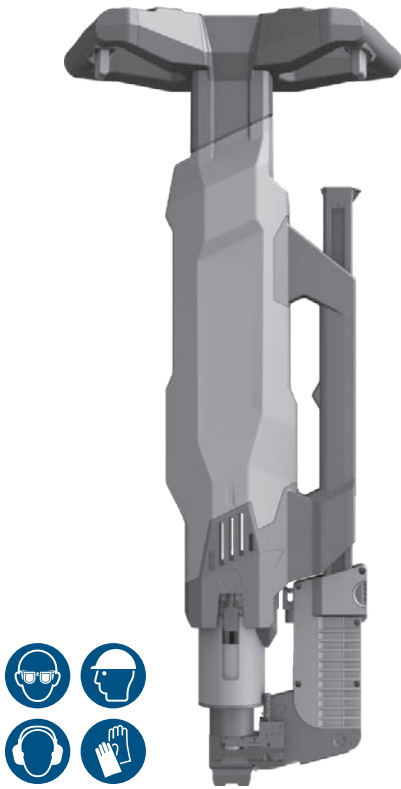

X-HSN nail / clou / clavo



6.8 /11 M40 cartridge / cartouche / cartucho



Cartridge selection / Choix de cartouches / Selección del cartucho

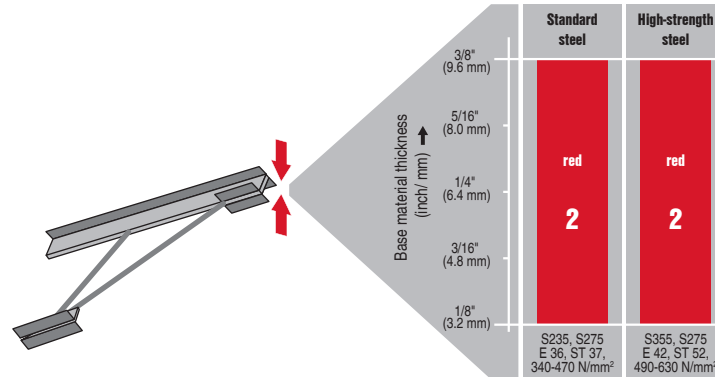

1.0 Preparation / Préparation / Preparación

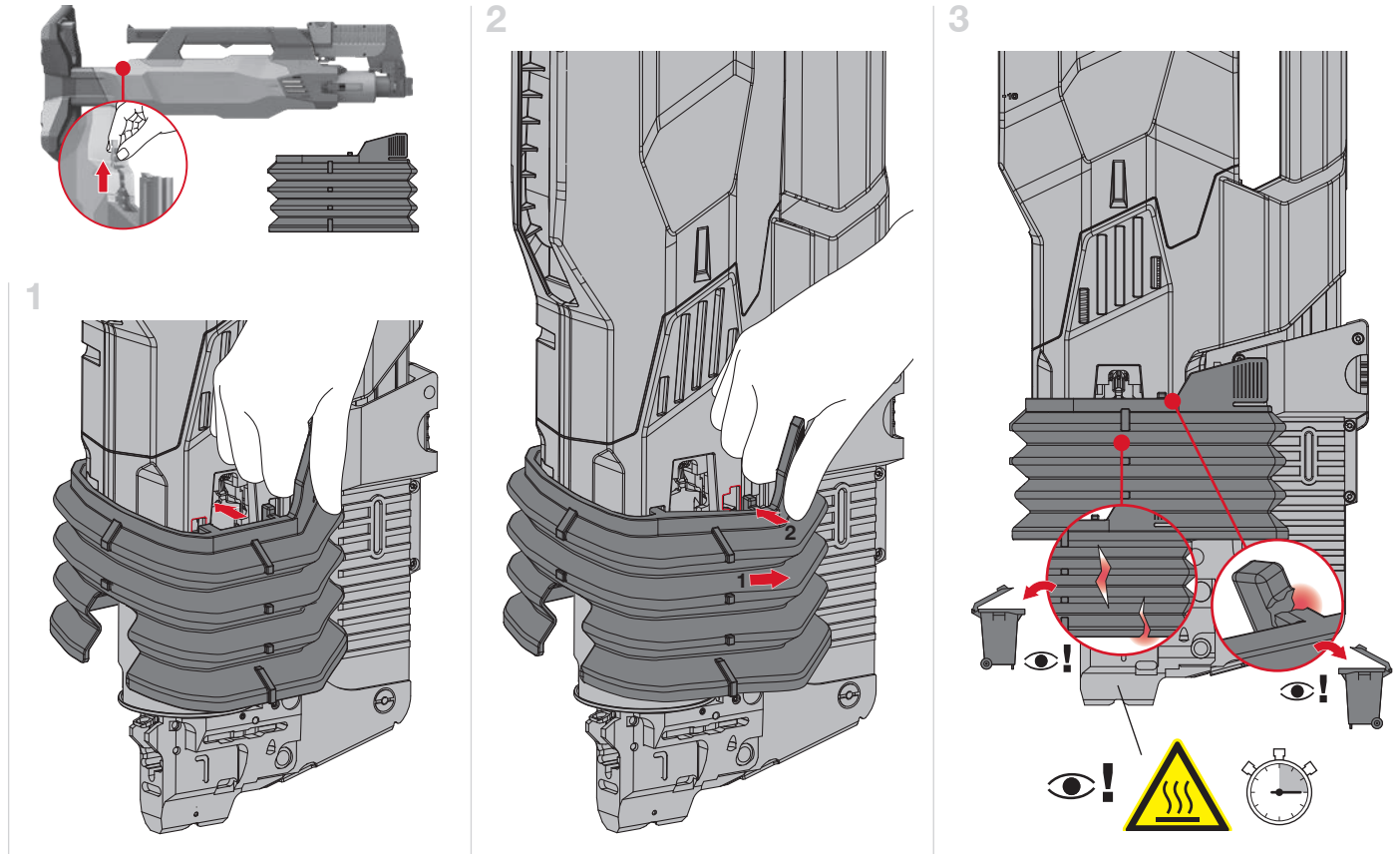

1.0 Preparation / Préparation / Preparación

1

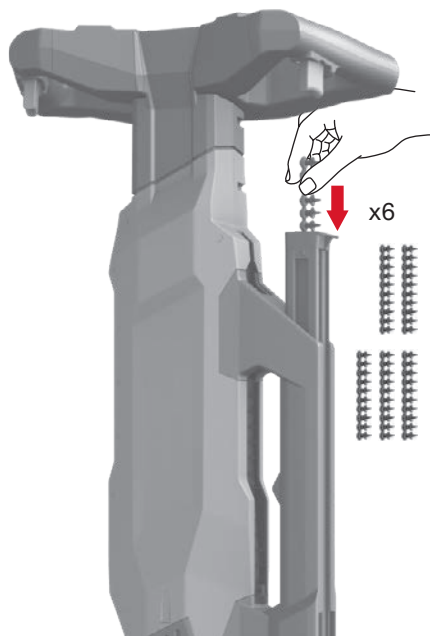

2

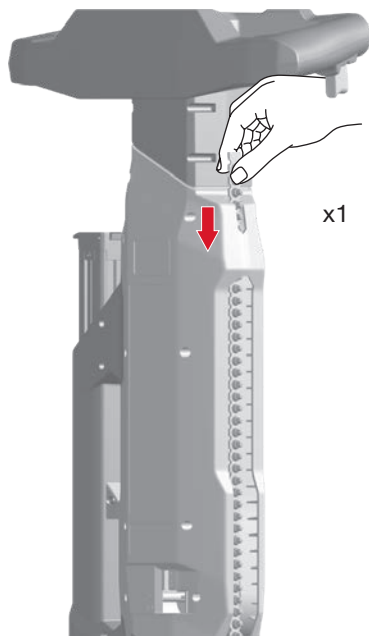

3

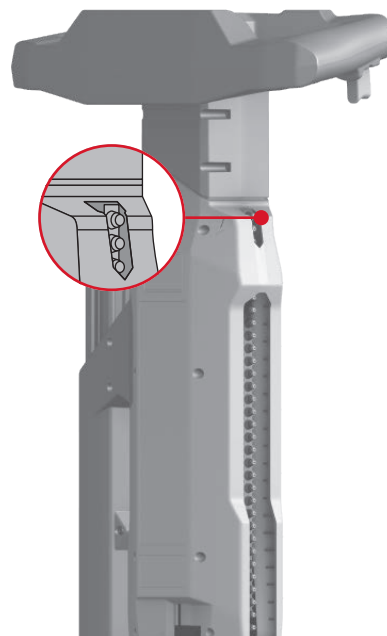

2.0 Installation / Installation / Instalación

1

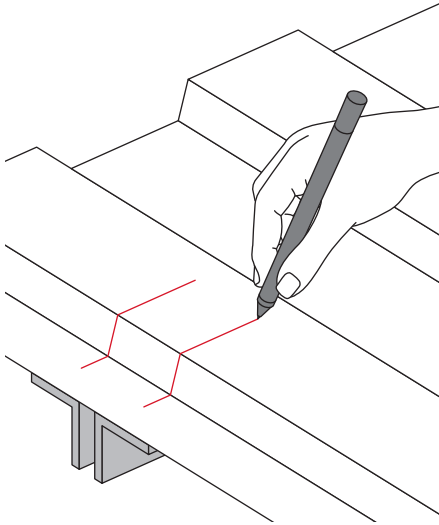

2

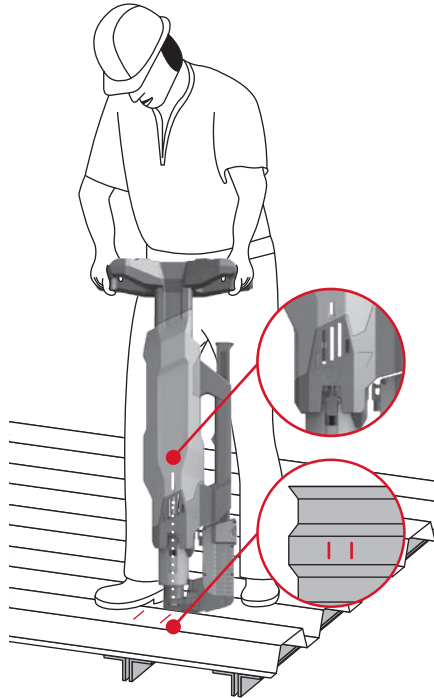

3

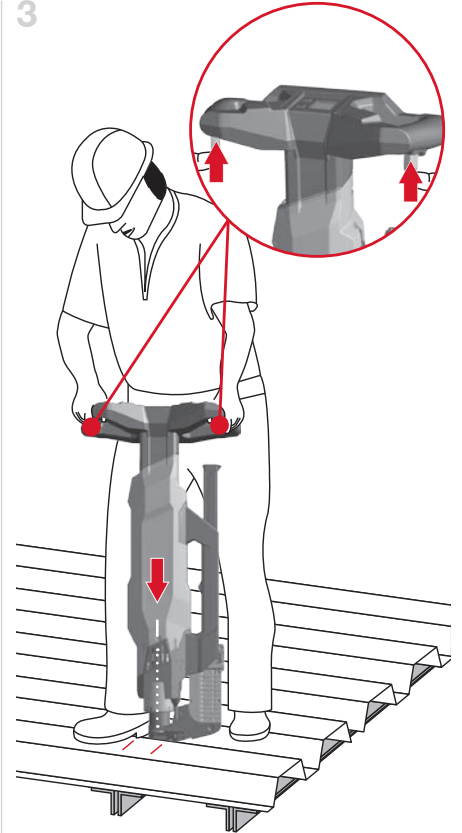

2.0 Installation / Installation / Instalación

4

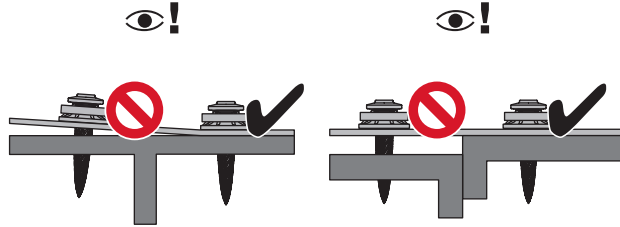

5

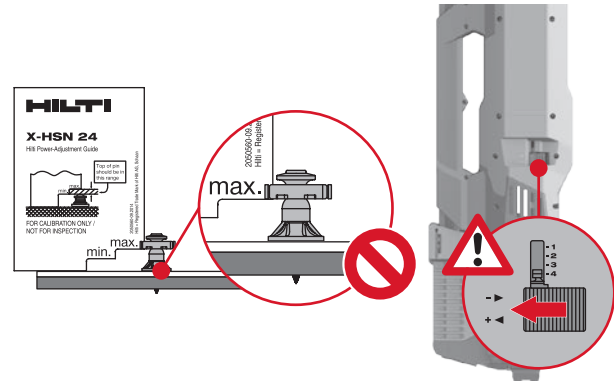

6

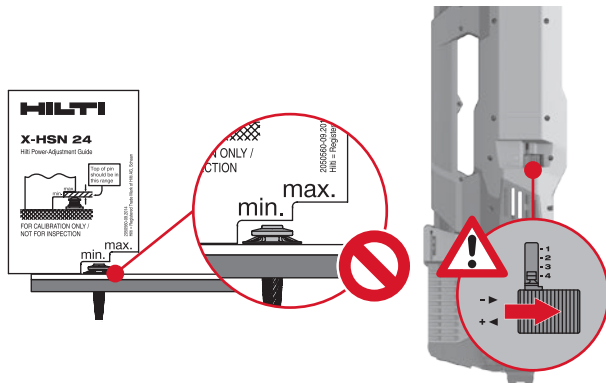

7

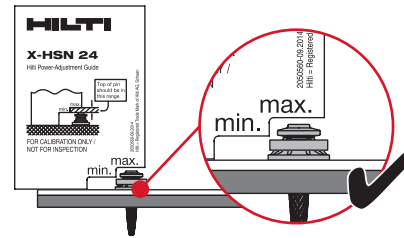

3.0 Operation / Fonctionnement / Operación

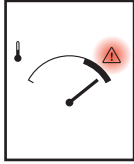
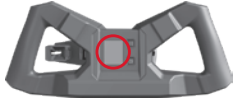

1

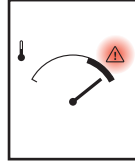

2

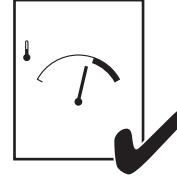

4.0 Unloading the tool / Déchargement de l'outil / Descarga de clavos herramienta

1

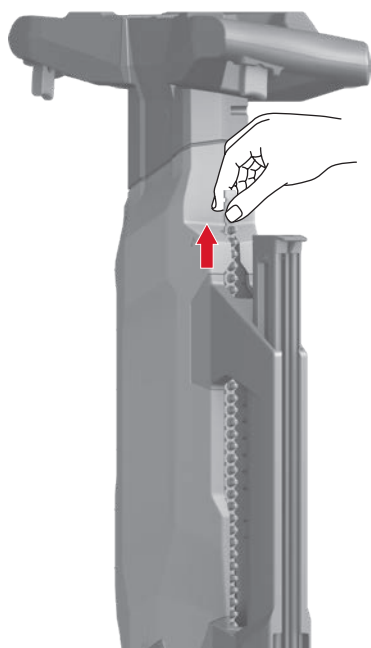

2

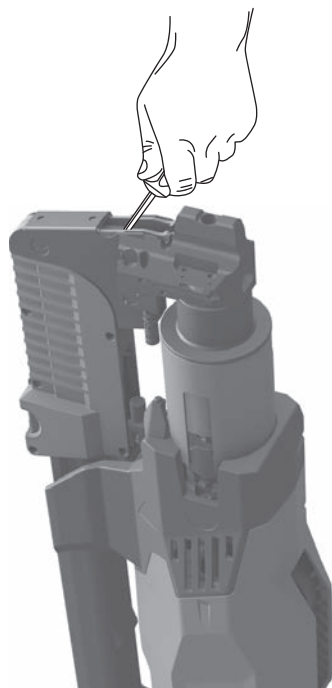

3

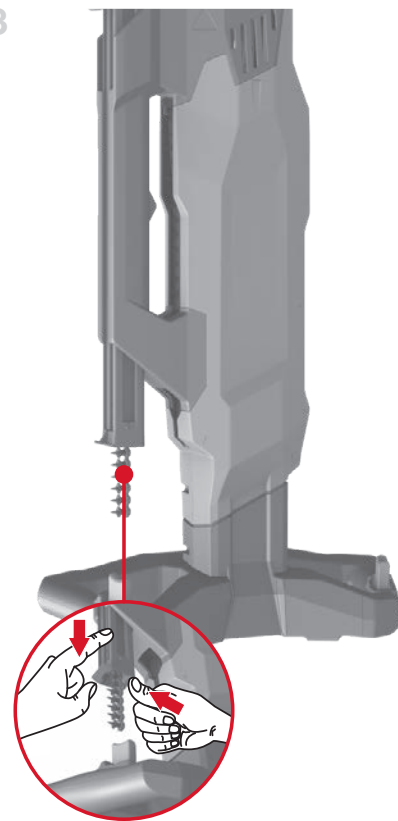

5.0 Disassembly / Désassemblage / Desmontaje

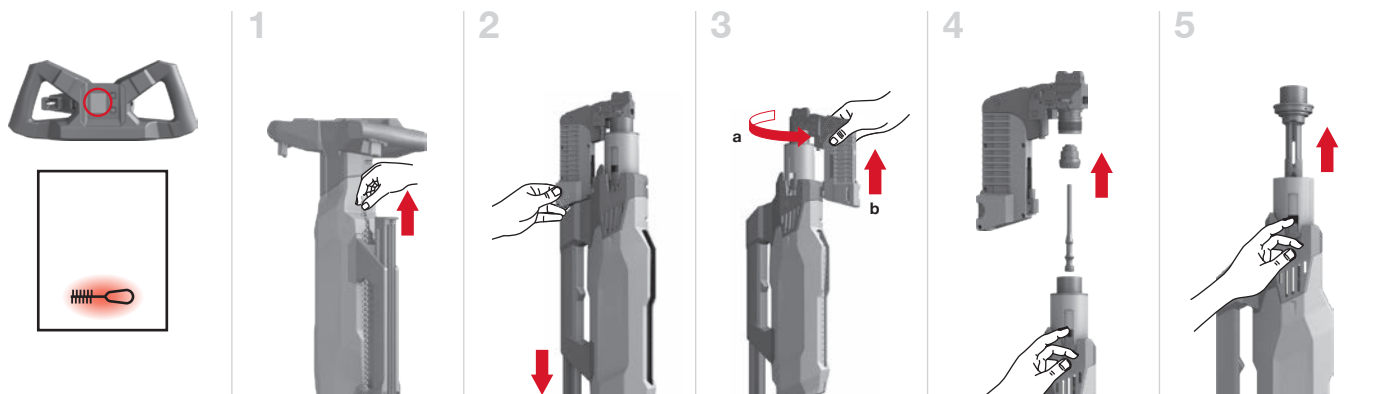

6.0 Cleaning / Nettoyage / Limpieza

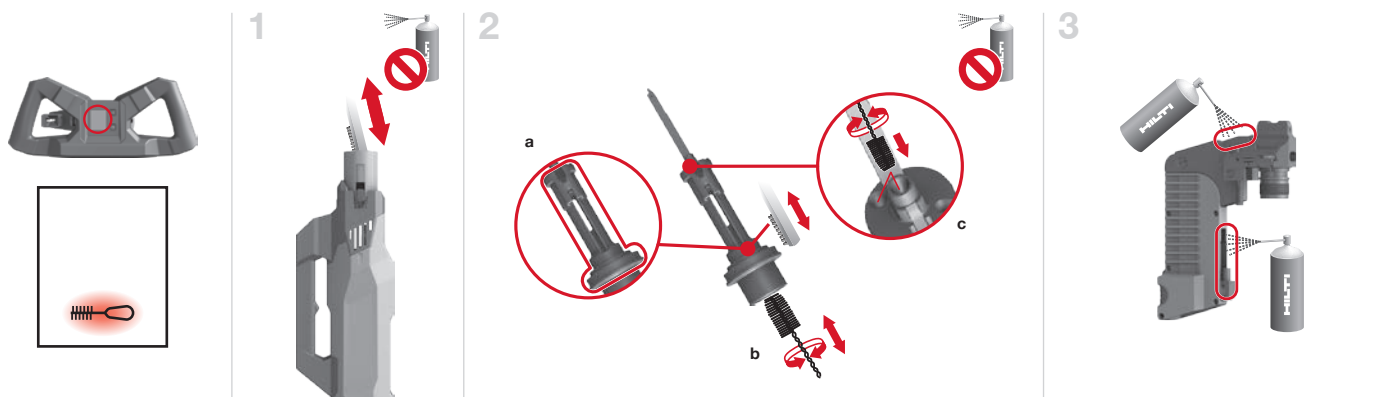

7.0 Checking pistons & Piston break / Vérification des pistons & Butée de piston / Verificación del piston & Anillo de retención



8.0 Assembly / Assemblage / Ensamblaje

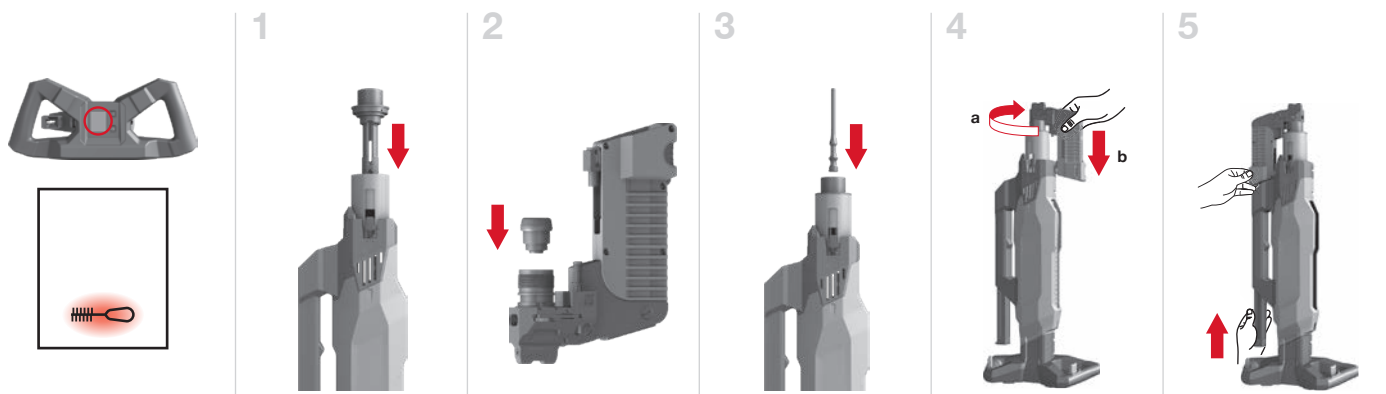

9.0 Service / Entretien / Servicio

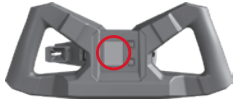

2



3

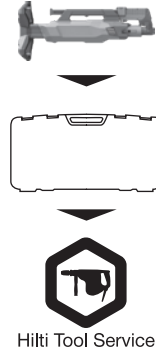

10.0 Piston jam – tool stays compressed / Piston coincé – outil coincé en position comprimée / Pistón atorado – La herramienta permanece comprimida

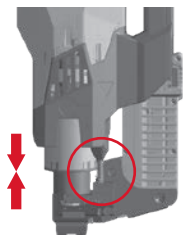

1

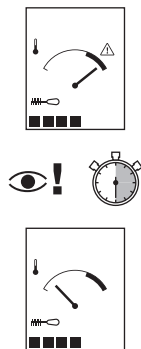

2

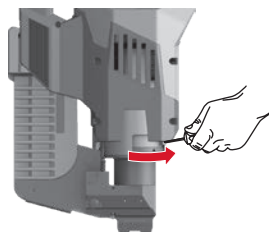

3

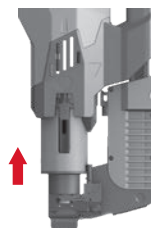

4

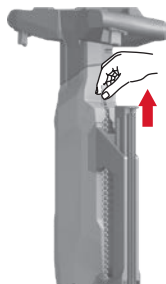

5

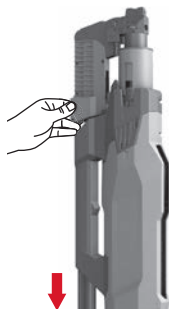

6

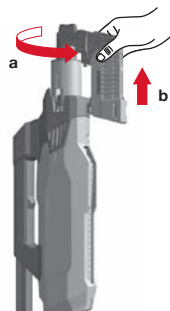

7

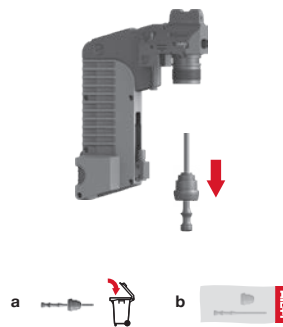

11.0 Tool cannot be compressed / Impossible de comprimer l'outil / La herramienta no se puede comprimir

1

2

3

4

5

6

If not working
L'outil ne fonctionne pas
Si no funciona

Hilti Tool Service

